

IP09 FUSION

INSTALLATION INSTRUCTIONS

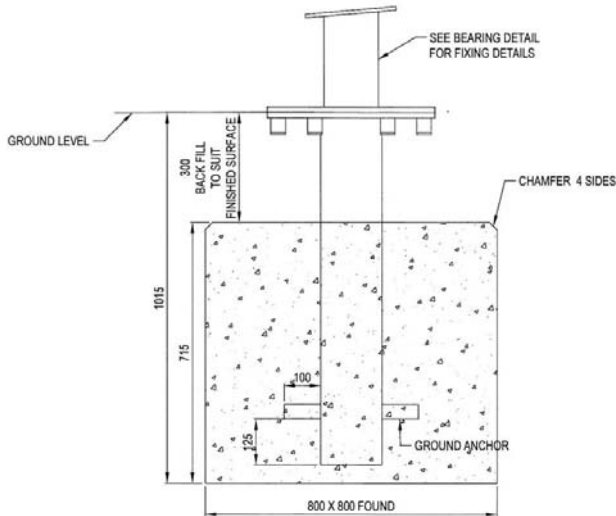

IP09 Fusion 1.3m diameter dish



14 / SCREW M16 X 45 INTO TOP BEARING PLATE AND FIT NYLOCK NUT TO UNDERSIDE.

11 / SCREW M16 X 40 INTO TOP GROUND ANCHOR PLATE.

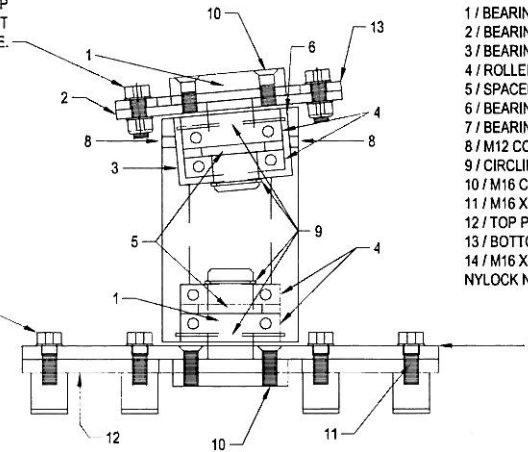

- 1 / BEARING SHAFT
- 2 / BEARING TOP PLATE TAPPED M16
- 3 / BEARING SLEEVE
- 4 / ROLLER BEARING
- 5 / SPACER
- 6 / BEARING HOUSING
- 7 / BEARING BASE PLATE
- 8 / M12 CONE SETSCREWS
- 9 / CIRCLIP
- 10 / M16 CSK SOCKET SCREW
- 11 / M16 X 40 SOCKET SCREW WITH WASHER
- 12 / TOP PLATE GROUND ANCHOR
- 13 / BOTTOM PLATE SPINNER
- 14 / M16 X 45 SOCKET SCREW WITH WASHERS AND NYLOCK NUT

The ground anchor should be allowed to set in the concrete for 120 hours before fixing the main assembly

No. of People required: 4

No. of Hours required: 3
(123 inc. concrete curing)

Overall unit weight: 240kg



HEAVY

(requires mechanical lifting)



www.inclusiveplay.com

IP09 FUSION

INSTALLATION INSTRUCTIONS

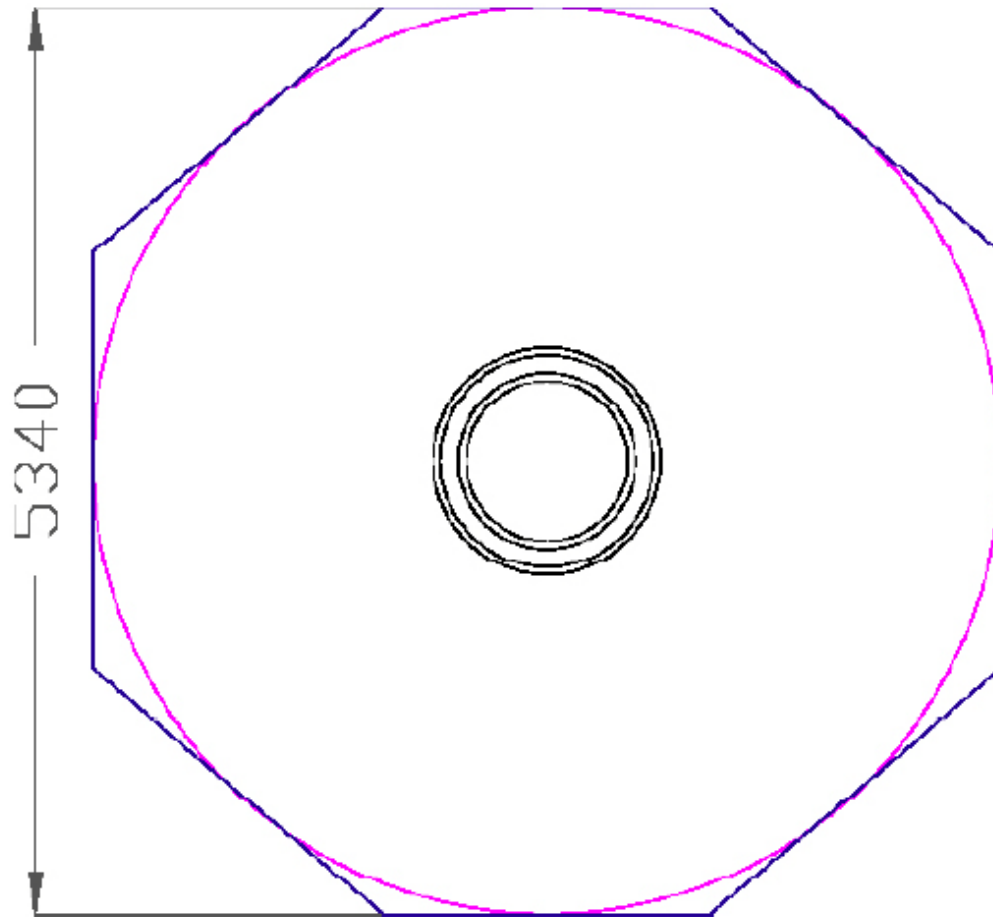

Freespace and Surfacing = 29m²

Critical Fall Height = 800mm



www.inclusiveplay.com